

SEQUENCE TIMING CONTROL

MODEL 606133J

3 OUTPUT SOLID STATE PROGRAM TIMER

ENCAPSULATED

RELAY AND SOLID STATE OUTPUTS

- ENVIRONMENT PROTECTED
- TAMPER PROOF
- NO FALSE OPERATE
- SIZE 3" x 4.5" x 1.25"
- RUGGED
- WEIGHT APPROXIMATELY 10 OZ.
- TRANSIENT PROTECTED
- 1/4 FASTON TERMINALS

This timing control provides a repeat cycle of outputs in a fixed sequence. When input power is applied the OUTPUT1 closes the normally open contact for a fixed short period of ON Time. This is followed by an Off Time during which the n/o relay contact is open. This cycle will continue until power is removed. During the next part of the cycle there is a Delay Time during which no outputs are active. Following this delay time there is a Load 1 which is energized for a preset period of time. The Load 2 on time immediately follows the end of the load 1 time. Both the Load 1 and Load 2 on times are either fixed or adjustable.

Timing is predetermined before assembly and is somewhat flexible with respect to initial requirements. The sequence of events within the cycle can under certain circumstances be varied. Many other sequence and time variations are possible when the factory is consulted. The Output 1 relay n/o contact is rated at 10 amps. The load 1 and load 2 output solid state switches are rated at 1 amp. This control was originally applied to control the fresh vegetable misting in super markets, etc.

TIMING DIAGRAM

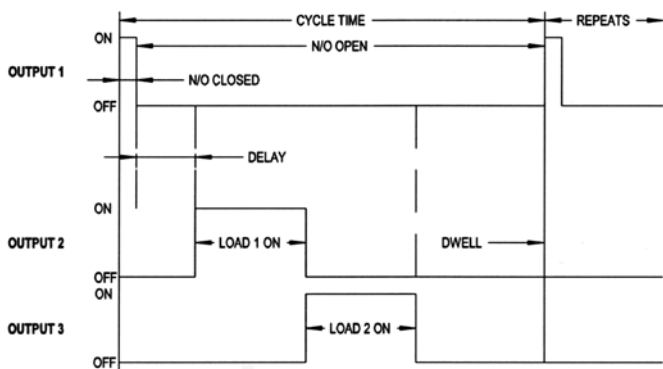

SPECIFICATIONS

1. Repeat Accuracy: $\pm 0.25\%$
2. Combined Effect of Temperature and Voltage upon Repeat Accuracy: $\pm 2\%$ of Setting
3. Reset Time: 300 ms.
4. Operating Voltage Tolerance: $\pm 20\%$
5. Relay Load Current: 10 Amps Resistive at 120VAC, & 28VDC
6. Solid State Load Current: 8 ma. Min., 1.0 Amp Max.
7. Solid State Leakage Current: 5 ma.
8. Dielectric Strength: 1500V RMS
9. Insulation Resistance: 100 Megohms Min.
10. Input Transient Protection: 3000v, 120V Units.
11. Humidity—Operating: 95% Relative
12. Timing Tolerance: $\pm 9\%$ + Tolerance of Rt Std., $\pm 5\%$ (Special) Fixed

HOW TO ORDER: SPECIFY THE FOLLOWING FROM THE TABLE BELOW; INPUT VOLTAGE, T1 ON & OFF TIME, FIXED DELAY TIME, T2,T3 ON TIME AND ANY OPTIONS.

INPUT VOLTAGE	T1 ON TIME	T1 OFF TIME	DELAY TIME	T2 ON TIME	T3 ON TIME	P = OPTIONS
4 = 24VAC	1 = .1-10 SEC	3 = 10-1000 SEC	1 = .1-10 SEC	1 = .1-10 SEC.	1 = .1-10 SEC	C = FIXED TIMES
5 = 120VAC	2 = 1-100 SEC	4 = .1-10 MIN	2 = 1-100 SEC	2 = 1-100 SEC.	2 = 1-100 SEC	O = ADJ. T1 OFF, T2, T3
1 = 12VDC		5 = 1-100 MIN		3 = 10-1000 SEC.	3 = 10-1000 SEC.	
2 = 24VDC						

EXAMPLE: 606133J - 14121CCCOO/2S10M6S, This is a Sequence Timing Control with T1 On Time 2 seconds fixed and T1 Off Time 10 minutes fixed, Delay Time 6 seconds fixed, T2 On Time adjustable 1-100 seconds, T3 On Time adjustable .1-10 seconds. The Input Voltage is 24VAC. Please note that the sum of Delay Time + T2 + T3 must not exceed T1 Off Time.

AMERICAN CONTROL PRODUCTS

A DIV. OF PRECISION TIMER CO., INC.
47 WESTBROOK INDUSTRIAL PARK ROAD
WESTBROOK, CT. 0649

PHONE: (860)399-6253

EMAIL: info@precisiontimer.com

FAX: (860)399-5619

WEB SITE: www.precisiontimer.com

TECHNICAL BULLETIN

SOLID STATE TIMING MODULE

PAGE 1
OF 2

DATE
9/12/03

606133J

REV

