



FILE LR28020

CAM PROGRAM TIMERS

Synchronous Motor Driven



FILE E47690

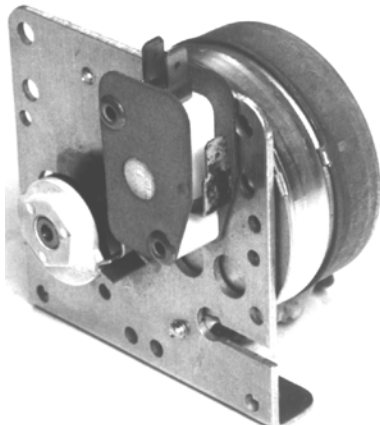

Series G150

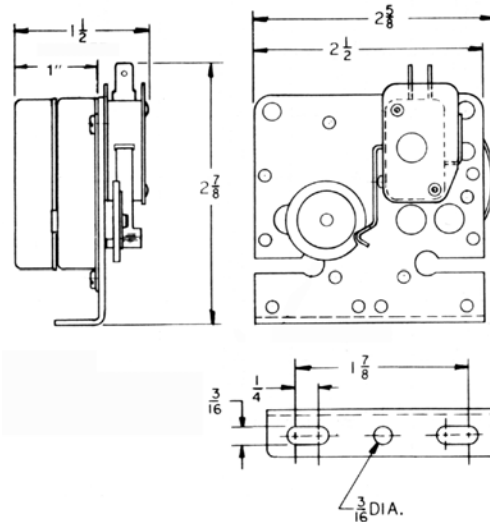

Series	No. of Poles	Sub – Basic Switches		
		V1 10 Amp	W2 15 Amp	H2 21 Amp
G150	1 POLE ONLY	G150 – V1	G150 – W2	G150 – H2

When energized a Program Timer repeats continuously and synchronously, a pre-established sequencing of ON/OFF switching events. Also known as Cam or Multi-cam Timer, Flasher, Cycle or Re-cycle Timer, or Repeat Cycle Timer. One "cycle" is one revolution of the output cam shaft. These may be wired for single revolution and stop operation (see Homing). An external momentary pushbutton wired as shown on Homing will cause the camshaft to rotate 1 revolution only and come to an abrupt halt. During this cycle the cam performs the prescribed sequence of operations. This popular wiring is typified in cup dispensing coffee vending machinery.

TYPICAL TIMING

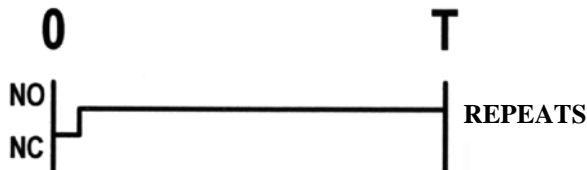

TYPICAL WIRING

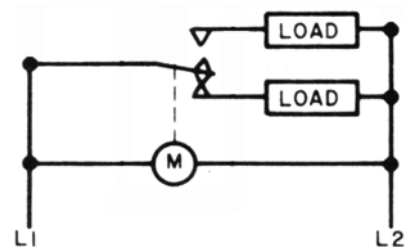

HOW TO ORDER: G150-(SW)/CYCLE TIME V HZ – SUFFIX

SERIES	NO. OF POLES	SWITCH TYPE	CYCLE TIME	VOLTS	HZ	SUFFIX
G150	SINGLE	V1	AS REQUIRED	L = 24V	5 = 50HZ	FACTORY
	POLE	W2	BY CUSTOMER	D = 120V	6 = 60HZ	ASSIGNED
	ONLY	H2		E = 230V	7 = 50-60HZ	AS REQUIRED

EXAMPLE: G150H2/10MD6 Series G150, Switch Rated 21 Amp, 10 Minute Cycle, 120V, 60Hz

MADE IN USA

AMERICAN CONTROL PRODUCTS

A DIV. OF PRECISION TIMER CO., INC.
47 WESTBROOK INDUSTRIAL PARK ROAD
WESTBROOK, CT. 06498

PHONE: (860)399-6253

EMAIL: info@precisiontimer.com
WEB SITE: www.precisiontimer.com

FAX: (860)399-5619

TECHNICAL BULLETIN

CAM PROGRAM TIMERS

PAGE 1
OF 2

DATE
2/25/03

G150

REV



FILE LR28020

RATINGS AND OPERATIONAL PARAMETERS



FILE E47690

Motors

- Permanent magnet synchronous inductor type.
- USA industrial standard pear-shaped configuration.
- UL and CSA approved.
- Enclosed construction.
- Rated 3 watts @ 120/60 VAC.
- Torque rating 30 inch-ounces at 1 RPM.
- Stocked and standard at 120/60.
- Also readily available or stocked for 24/60, 230/60, 24/50, 115/50, and 220/50.
- These motors operate at a speed precisely synchronous with frequency of input power.
- Special motors available on request, such as reversible, variable speed, extra fast, extra slow, hi-torque, direct current, etc.
- Corrosion resistant.
- Tough, reliable, long-lived.
- Reasonable life expectancy exceeding 10,000 hours.
- Fast acceleration. Instant stop.
- Our staff filters all incoming orders to ensure adequate motor torque.

Switches (All switches are UL and CSA approved)

V1 – 10 Amperes

- UL rated 10 amperes nominal @ .75 power factor.
- ½ horsepower at 125/250 VAC.
- Enclosed, snap-action, sub-basic size.
- .187 male push-on terminals.
- Form C – SPDT.

W2 – 15 Amperes

- UL rated 15 amperes nominal @ .75 power factor.
- ½ horsepower at 125/250 VAC.
- Enclosed, snap-action, sub-basic size.
- .250 Male push-on terminals.
- Form C – SPDT.

H2 – 21 Amperes

- UL rated 21 amperes nominal @250VAC.
- 1hp @ 125 VAC, 2hp @ 250VAC.
- Enclosed, snap-action, sub-basic size.
- .250 male push-on terminals.
- Form C – SPDT.

E – 25 Amperes

- UL rated 25 amps @ 125,250 or 480 VAC.
- 1 hp @ 125 VAC or 2 hp @ 250 VAC.
- Pilot duty 750 VA @ 125 or 250 VAC.
- Enclosed snap-action, full basic size, # 8 screw terminals.
- Form C – SPDT.
- For restricted uses only.

Life Expectancy

The life of a switch is a function of the type, magnitude, and number of usages under an applied electrical load. At low electrical load 95% survival is expected at 10,000,000 operations, at full electrical load 95% survival is expected at 150,000 operations, subject to inrush considerations and type of load as to resistive, inductive, or capacitive. Particular attention should be given for high inrush applications such as heaters or lamps as might weld, erode, or cavitate switch contacts. We will gladly assist customers in making a selection.

Camshaft Speed (Time per Cycle)	No. of Switch Operations in One Year	
	Continuous Operation	Fifty 40-hour Weeks
1 sec.	31,557,600	7,200,000
15 sec.	2,103,840	480,000
30 sec.	1,051,920	240,000
1 min.	525,960	120,000
15 min.	35,064	8,000
30 min.	17,532	4,000
1 hr.	8,766	2,000
15 hrs.	584	133
30 hrs.	292	67

Cams

Standard Cams

- Molded nylon with approx. 180° cuts, 7/8" diameter.
- Color coded black and white.

Special Cams

- Standard 7/8" diameter or jumbo 1½" diameter.
- Multiple machined cuts – on special order.
 - Symmetrical
 - Asymmetrical

CAUTION: Big cams do NOT promote accuracy!

MADE IN U.S.A

AMERICAN CONTROL PRODUCTS

A DIV. OF PRECISION TIMER CO., INC.
47 WESTBROOK INDUSTRIAL PARK ROAD
WESTBROOK, CT. 06498

PHONE: (860)399-6253

FAX: (860)399-5619

EMAIL: info@precisiontimer.com
WEB SITE: www.precisiontimer.com

TECHNICAL BULLETIN

CAM PROGRAM TIMERS

PAGE 2
OF 2

DATE
2/25/03

G150

REV