



FILE LR28020

HAND - SET PERCENT TIMERS FOR PANEL MOUNT INSTALLATIONS

CALUS
FILE E47690

SERIES PER

Hand Set Dial Adjusts The Percent Time. The Dial Remains Stationary During Timing and Retains The Setting.

Offers many selections among optional features

- Choice among several front - panel styling and installation arrangements.
- Interchangeable in field or factory with all known competitive major brands.
- Single pole double throw form C switch
- Switch is rated at 10,15 or 21 amperes with .187" or .250" male push-on termination.
- Broad selection of time ranges.
- All international voltages and frequencies.



AVAILABLE WITH
HIGH- STYLED
BLACK PLASTIC
FRONT END



AVAILABLE WITH
ALUMINUM DIAL
AND BEZEL
ECONOMY FRONT
END

TIMING DIAGRAM
(TYPICAL)

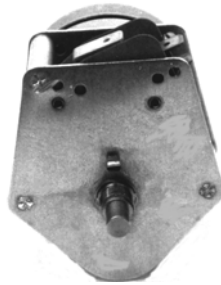
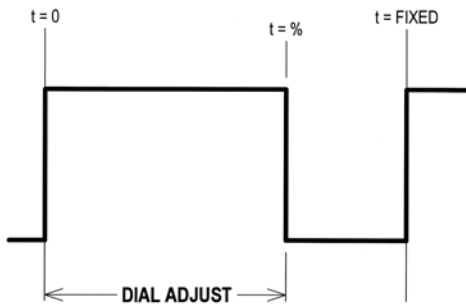

AVAILABLE WITHOUT
A DIAL

WIRING DIAGRAM
(TYPICAL)

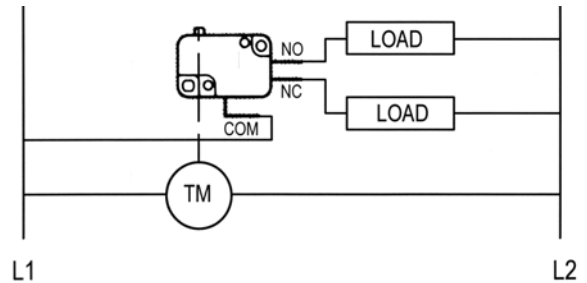

OPERATION

Provides an adjustable PERCENTAGE of "ON" and "OFF" time during each rotation of the camshaft which is revolving at a fixed synchronous speed. During each revolution of the camshaft a triggering mechanism transfers the switch at a fixed point, holding this position until it passes a release point which is hand set by the front dial. This dial is calibrated into 100 divisions.

Applications include metering and proportioning, oven and heating controls, attic fans, cattle feeding machinery, automation, and water softeners.

HOW TO ORDER: PER (SW) / (T) (V) (HZ) (O) (S)

SERIES	SW = SWITCH TYPE	T = TIME PER CYCLE	V = AC VOLTS	HZ = HERTZ	O = OPTIONS	S = SUFFIX
PER	V1	AS	L = 24V	5 = 50 HZ	CONSTRUCTION	FACTORY
	W2	REQUIRED BY	D = 120V	6 = 60 HZ	OR DIAL	ASSIGNED
	H2	CUSTOMER	E = 230V	7 = 50-60 HZ	SEE	AS REQUIRED
		SELECT FROM			OUTLINE	
		5 SEC. TO 4 DAYS			DRAWINGS	

EXAMPLE: PERW2/60MD6A; Series PER, SPDT Switch, Rated 15 Amp, 60 Minutes Interval, 120 Volts, 60Hz, Economy Front End.

MADE IN USA

AMERICAN CONTROL PRODUCTS
A DIV. OF PRECISION TIMER CO., INC.
47 WESTBROOK INDUSTRIAL PARK ROAD
WESTBROOK, CT. 06498

PHONE: (860)399-6253

FAX: (860)399-5619

EMAIL: info@precisiontimer.com
WEB SITE: precisiontimer.com

TECHNICAL BULLETIN

PANEL MOUNTED INTERVAL TIMERS

PAGE 1
OF 4

DATE
5/27/03

PER

REV



FILE LR28020

SERIES PER OUTLINE DRAWINGS

CAUS
FILE E47690

INSTALLATION ARRANGEMENT "R"

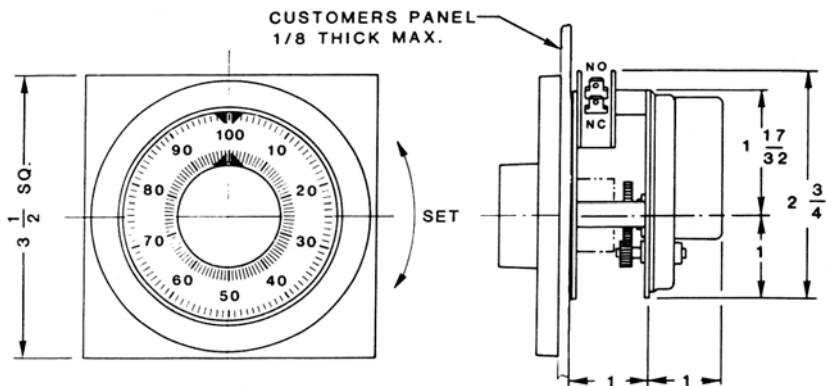

HANDSOME PANEL STYLING FEATURING A BLACK PLASTIC BEZEL WITH CONTRASTING DIAL

REASONABLY PRICED
INEXPENSIVE TO INSTALL FROM REAR OF PANEL

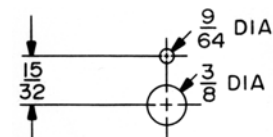

MOUNTING DIMENSIONS

INSTALLATION ARRANGEMENT "S"

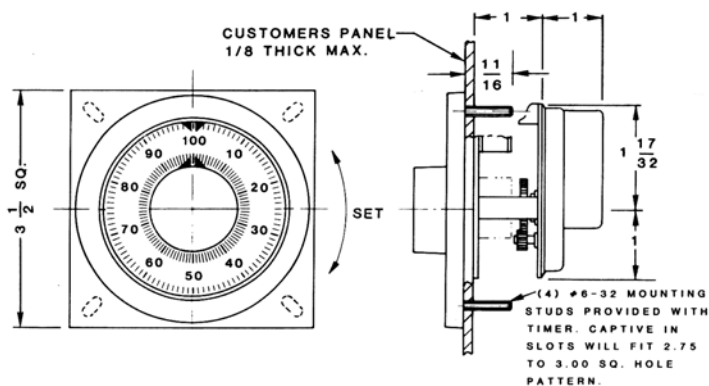

FEATURES A BLACK PLASTIC BEZEL WITH CONTRASTING DIAL AND 4 ADJUSTABLE STUDS

MOUNTING IS FROM THE FRONT OF THE PANEL

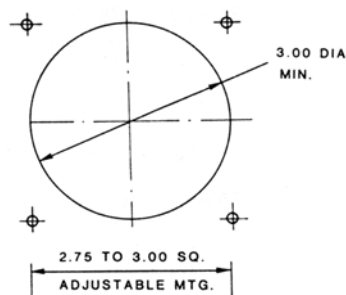

This installation arrangement "S" is interchangeable with many competitive brands. Four # 6-32 studs are provided, captive in slots, and they will adjust freely to match any square pattern from 2.75" square to 3.00" square. The plastic front bezel will cover and hide any existing central body clearance hole up to 3 1/2" diameter.

INSTALLATION ARRANGEMENT "A"

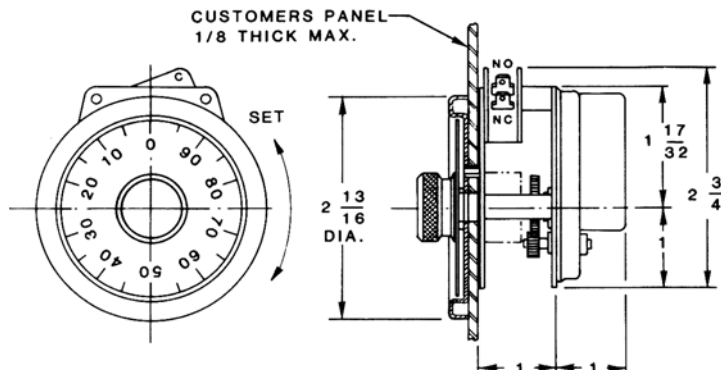

LOW COST ALUMINUM DIAL AND BEZEL FRONT END
VERY INEXPENSIVE TO INSTALL FROM REAR OF PANEL

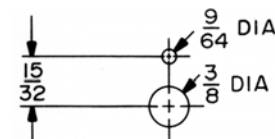

MOUNTING DIMENSIONS

MADE IN USA

AMERICAN CONTROL PRODUCTS
A DIV. OF PRECISION TIMER CO., INC.
47 WESTBROOK INDUSTRIAL PARK ROAD
WESTBROOK, CT. 06498

PHONE: (860)399-6253

EMAIL: info@precisiontimer.com
WEB SITE: precisiontimer.com

FAX: (860)399-5619

TECHNICAL BULLETIN

PANEL MOUNTED INTERVAL TIMERS

PAGE 2
OF 4

DATE
5/27/03

PER

REV



FILE LR28020

SERIES PER OUTLINE DRAWINGS



FILE E47690

INSTALLATION ARRANGEMENT "B"

BARE TIMER WITHOUT A DIAL AND BEZEL
CUSTOMER WILL PROVIDE THE FRONT END DECOR

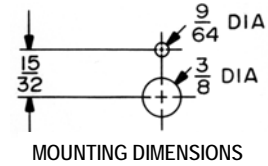
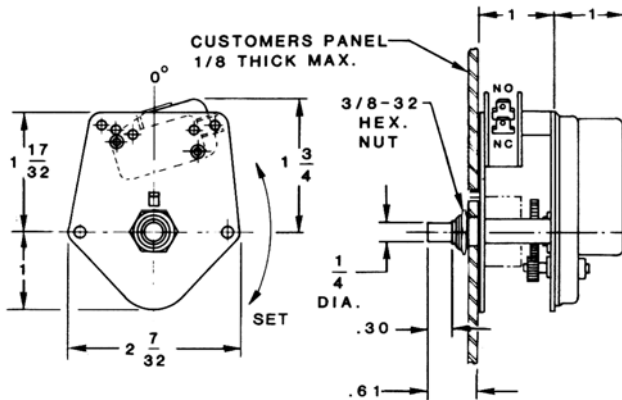

INSTALLATION ARRANGEMENT "X"

ANY OTHER MOUNTING ARRANGEMENT – We can provide numerous other mounting arrangements and front-end designs. Please ask the factory about any special arrangement needed but not illustrated above.

MADE IN USA

AMERICAN CONTROL PRODUCTS
 A DIV. OF PRECISION TIMER CO., INC.
 47 WESTBROOK INDUSTRIAL PARK ROAD
 WESTBROOK, CT. 06498

PHONE: (860)399-6253

EMAIL: info@precisiontimer.com
 WEB SITE: precisiontimer.com

FAX: (860)399-5619

TECHNICAL BULLETIN

PANEL MOUNTED INTERVAL TIMERS

PAGE 3
OF 4

DATE
5/27/03

PER

REV



RATINGS AND OPERATIONAL PARAMETERS

MOTORS

- Permanent magnet synchronous inductor type.
- USA industrial standard pear-shaped configuration.
- UL and CSA approved.
- Enclosed construction.
- Torque rating 30 inch-ounces at 1 RPM.
- Stocked and standard at 120/60.
- Also readily available or stocked for 24/60, 230/60, 24/50, 115/50, and 220/50.
- These motors operate at a speed precisely synchronous with frequency of input power.
- Corrosion resistant.
- Tough, reliable, long lived.
- Reasonable life expectancy exceeding 10,000 hours.
- Fast acceleration. Instant stop.
- Our staff filters all incoming orders to insure adequate motor torque.

Switches (All switches are UL and CSA approved)

V1 – 10 Amperes

- UL rated 10 amperes nominal @ .75 power factor.
- ½ horsepower at 125/250 VAC.
- Enclosed, snap-action, sub-basic size.
- .187 male push-on terminals.
- Form C – SPDT.

W2 – 15 Amperes

- UL rated 15 amperes nominal @ .75 power factor.
- ½ horsepower at 125/250 VAC.
- Enclosed, snap-action, sub-basic size.
- .250 Male push-on terminals.
- Form C – SPDT.

H2 – 21 Amperes

- UL rated 21 amperes nominal @250VAC.
- 1hp @ 125 VAC, 2hp @ 250VAC.
- Enclosed, snap-action, sub-basic size.
- .250 male push-on terminals.

Life Expectancy

The life of a switch is a function of the type, magnitude, and number of usages under an applied electrical load. At low electrical load 95% survival is expected at 10,000,000 operations, at full electrical load 95% survival is expected at 150,000 operations, subject to inrush considerations and type of load as to resistive, inductive, or capacitive. Particular attention should be given for high inrush applications such as heaters or lamps as might weld, erode, or cavitate switch contacts. We will gladly assist customers in making a selection.

Camshaft Speed (Time per Cycle)	No. of Switch Operations in One Year	
	Continuous Operation	Fifty 40-hour Weeks
1 sec.	31,557,600	7,200,000
15 sec.	2,103,840	480,000
30 sec.	1,051,920	240,000
1 min.	525,960	120,000
15 min.	35,064	8,000
30 min.	17,532	4,000
1 hr.	8,766	2,000
15 hrs.	584	133
30 hrs.	292	67

AMERICAN CONTROL PRODUCTS

A DIV. OF PRECISION TIMER CO., INC.
47 WESTBROOK INDUSTRIAL PARK ROAD
WESTBROOK, CT. 06498

PHONE: (860)399-6253

FAX: (860)399-5619

EMAIL: info@precisiontimer.com
WEB SITE: www.precisiontimer.com

TECHNICAL BULLETIN

PANEL MOUNTED INTERVAL TIMERS

PAGE 4
OF 4

DATE
5/27/03

PER

REV