

HIGH CURRENT TIMING RELAY

COOL DOWN TIMER ENCAPSULATED MODULE

10 AMPERE RATING

Series 842J – OFF DELAY

SOLID STATE CMOS DIGITAL CIRCUITRY



- Environment Protected
- Tamper Proof
- No False Operate
- Small Size – 2" x 2" x 15/16"
- Lightweight – approximately 2.5 oz.
- Rugged
- Transient Protected to 6000V

To operate input voltage is applied continuously. A normally open initiate switch closure causes the load contact to close, energizing the load. Timing will start when the initiate switch opens. At the end of the preset delay time period the load is turned OFF. A new cycle of operation can then be started via the initiate switch re-closure. Should the initiate switch be re-closed during the preset time delay period, timing will stop, but the load will remain energized. When the initiate switch is re-opened, the preset delay will re-triggered. When the delay time has reached time out, the load will be de-energized, and the timer is reset. This timer is commonly referred to as the "COOL DOWN TIMER". Control the timing of high power electric heaters, lamps, transformers and other high current loads rated less than 10 amps Resistive. CMOS digital circuitry is combined with high current output relay contacts. P/C board and internal components are encapsulated in a flame retardant molded housing, fitted with quick connect wiring terminals. Available in all standard voltages and frequencies. Fixed or adjustable timing from .1 seconds to 24 hours.

TIMING DIAGRAM

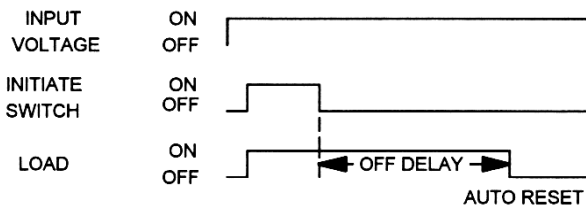

SPECIFICATIONS

1. Repeat Accuracy: $\pm 0.25\%$
2. Combined Effect of Temperature and Voltage upon Repeat Accuracy: $\pm 2\%$
3. Reset Time: 150 ms.
4. Operating Voltage Tolerance: $\pm 20\%$
5. Load Current: 10 Amps Resistive at 120VAC, 5 Amps Resistive at 240VAC & 28VDC
6. Dielectric Strength: 1500 VRMS
7. Insulation Resistance: 100 Megohms Min.
8. Input Transient Protection: 3000V 120V UNITS, 6000V 240V UNITS
9. Temperature Ambients: Operating -40°C to $+70^{\circ}\text{C}$ Storage -55°C to $+85^{\circ}\text{C}$
10. Humidity-Operating: 95% Relative
11. Linearity(Option A or D): $\pm 5\%$ Minimum from 10% to 90% of range

HOW TO ORDER 842J – (T) (V) (P)

SERIES	(T) = TIME RANGE	(V)=VOLTAGE	(P) = OPTIONS
842J	P = 0.1 - 5 SEC.	1 = 12VDC	O - CUSTOMER SUPPLIES OWN POTENTIOMETER OR RESISTOR A - POTENTIOMETER SUPPLIED AS LOOSE PART *B - EXTERNALLY INSTALLED RESISTOR *C - FACTORY FIXED INTERNAL D - TRIMMER POTENTIOMETER INSTALLED ON TERMINALS R - INTERNAL POTENTIOMETER WITH THRU SHAFT S - INTERNAL POTENTIOMETER WITH SCREWDRIVER SLOT <div style="border: 1px solid black; padding: 5px; text-align: center;"> <i>* For Fixed Time Specify The Value In Seconds, Minutes, Or Hours</i> </div>
	1 = 0.1 - 10 SEC.	2 = 24VDC	
	L = 0.2 - 20 SEC.	3 = 48VDC	
	J = 0.3 - 30 SEC.	4 = 24VAC	
	M = 0.6 - 60 SEC.	5 = 120VAC	
	2 = 1 - 100 SEC.	6 = 240VAC	
	K = 1.2 - 120 SEC.	7 = 110VDC	
	F = 2 - 180 SEC.		
	E = 3 - 300 SEC.		
	3 = 10 - 1000 SEC.		
	4 = 0.1 - 10 MIN.		
	G = 0.3 - 30 MIN.		
	H = 0.6 - 60 MIN.		
	5 = 1 - 100 MIN.		
	V = 3 - 300 MIN.		
	6 = 10 - 1000 MIN.		
D = 1 - 24 HRS.			

MADE IN USA

EXAMPLE P/N: 842J-32C/240SEC This is an OFF DELAY 10A Rated Timer with a fixed 240 second delay and an INPUT VOLTAGE of 24 VDC. The delay time is internally fixed.

AMERICAN CONTROL PRODUCTS
 A DIV. OF PRECISION TIMER CO., INC.
 47 WESTBROOK INDUSTRIAL PARK ROAD
 WESTBROOK, CT. 06498

PHONE: (860)399-6253
 EMAIL: info@precisiontimer.com

FAX: (860)399-5619
 Web Site: precisiontimer.com

TECHNICAL BULLETIN

SOLID STATE TIMING MODULE

PAGE 1
 OF 2

DATE
 6-4-01

842J

REV
 B

TYPICAL CALIBRATION RESISTANCE VS TIME

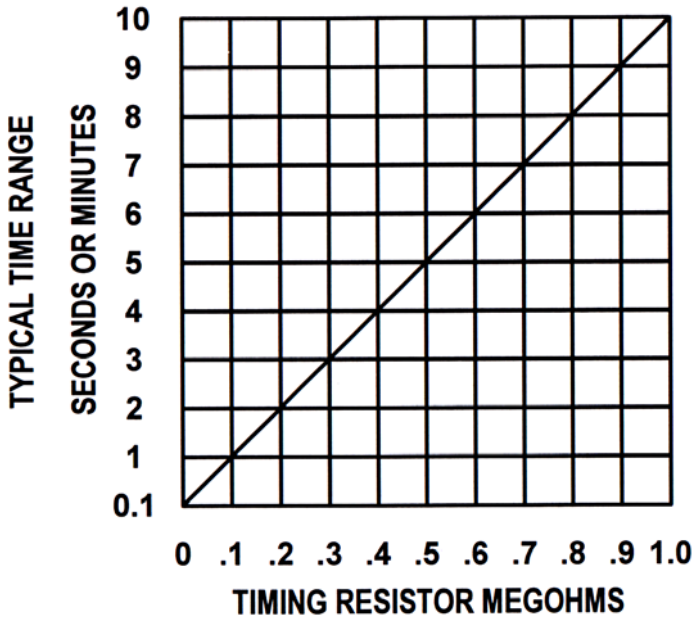

ACCESSORIES AVAILABLE FROM STOCK
CONTROL POTENTIOMETERS (OPTION A)
ORDER P/N PM-1M 1 MEGOHM $\pm 20\%$

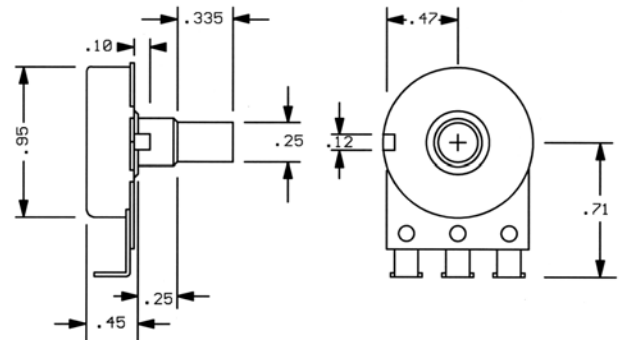

TYPICAL WIRING

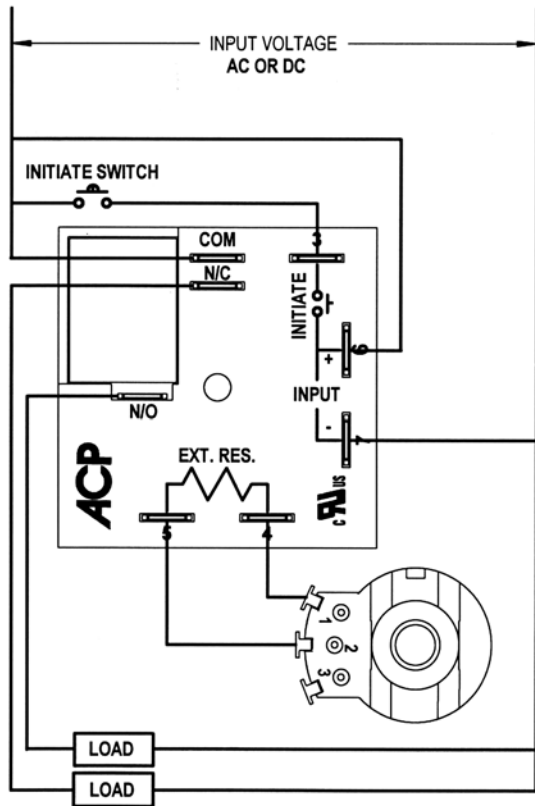

OUTLINE DRAWING

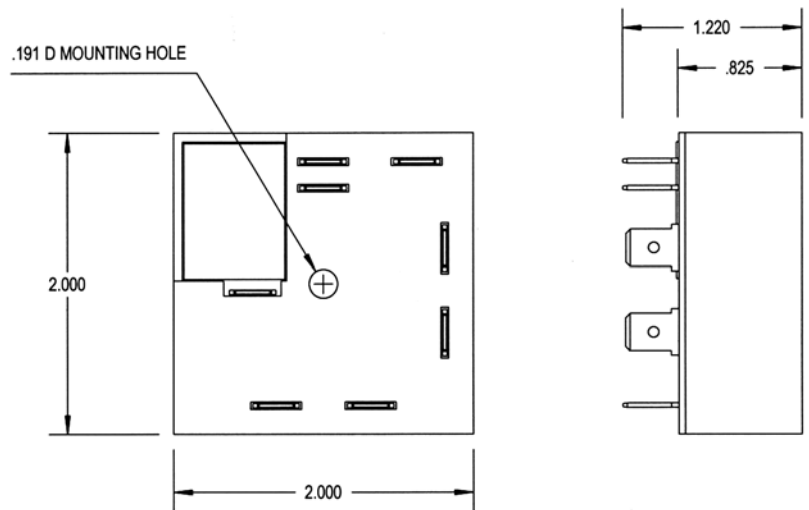

MADE IN USA

AMERICAN CONTROL PRODUCTS
A DIV. OF PRECISION TIMER CO., INC.
47 WESTBROOK INDUSTRIAL PARK ROAD
WESTBROOK, CT. 06498

PHONE: (860)399-6253
E-MAIL: info@precisiontimer.com

FAX: (860)399-5619
Web Site: precisiontimer.com

TECHNICAL BULLETIN

SOLID STATE TIMING MODULE

PAGE 2
OF 2

DATE
6-4-01

842J

REV
B